

SPECIFICATIONS

POLE SHAFT - Pole shaft is electro-welded ASTM-A500 Grade C steel tubing with a minimum yield strength of 50,000 psi. On Tenon Mount steel poles, tenon is 2-3/8" O.D. high-strength pipe. Tenon is 4-3/4" in length. Straight poles are 4", 5" and 6" square.

HAND HOLE - Standard hand-hole location is 12" above pole base. Poles 22' and above have a 3" x 6" reinforced hand-hole. Shorter poles have a 2" x 4" non-reinforced hand-hole.

BASE - Pole base is ASTM-A36 hot-rolled steel plate with a minimum yield strength of 36,000 psi. Two-piece square base cover is optional.

ANCHOR BOLTS - Poles are furnished with anchor bolts featuring zinc-plated double nuts and washers. Galvanized anchor bolts are optional. Anchor bolts conform to ASTM-A36 with a minimum yield strength of 36,000 psi.

GROUND LUG - Ground lug is standard.

DUPLEX RECEPTACLE - Weatherproof duplex receptacle is optional.

GROUND FAULT CIRCUIT INTERRUPTER - Ground fault circuit interrupter.

FINISH - Each pole is finished with WLS DuraGrip® polyester powder coat finishing process to give the pole an exceptionally attractive appearance. The process electrostatically applies and thermally fuses a polyester powder to the pole. This unique protection process provides an extremely smooth and uniform finish which withstands extreme weather changes without cracking or peeling. DuraGrip® finish features a five-year limited warranty. Standard finish colors available for poles are bronze, black, platinum plus, buff, white, satin verde green, metallic silver, and graphite. Optional DuraGrip® Plus features added protection with a 3.0 to 5.0 mil thickness of polyester-powder coat finish plus an inner coating. This specially designed inner coating is a thermal plastic hydrocarbon resin applied to the inside of the pole to seal and protect against atmospheric and corrosive matter. DuraGrip® Plus finish features a seven-year limited warranty.

DETERMINING THE LUMINAIRE/POLE COMBINATION FOR YOUR APPLICATION

- Select luminaire from Luminaire Ordering Information.
- Select bracket configuration.
- Refer to luminaire EPA chart to determine EPA value.
- Select height of pole.
- Select MPH to match the wind speed in the application area. (Windspeed Map located in Appendix)
- Confirm the pole EPA that is equal to or exceeds the luminaire/bracket EPA as was previously determined.

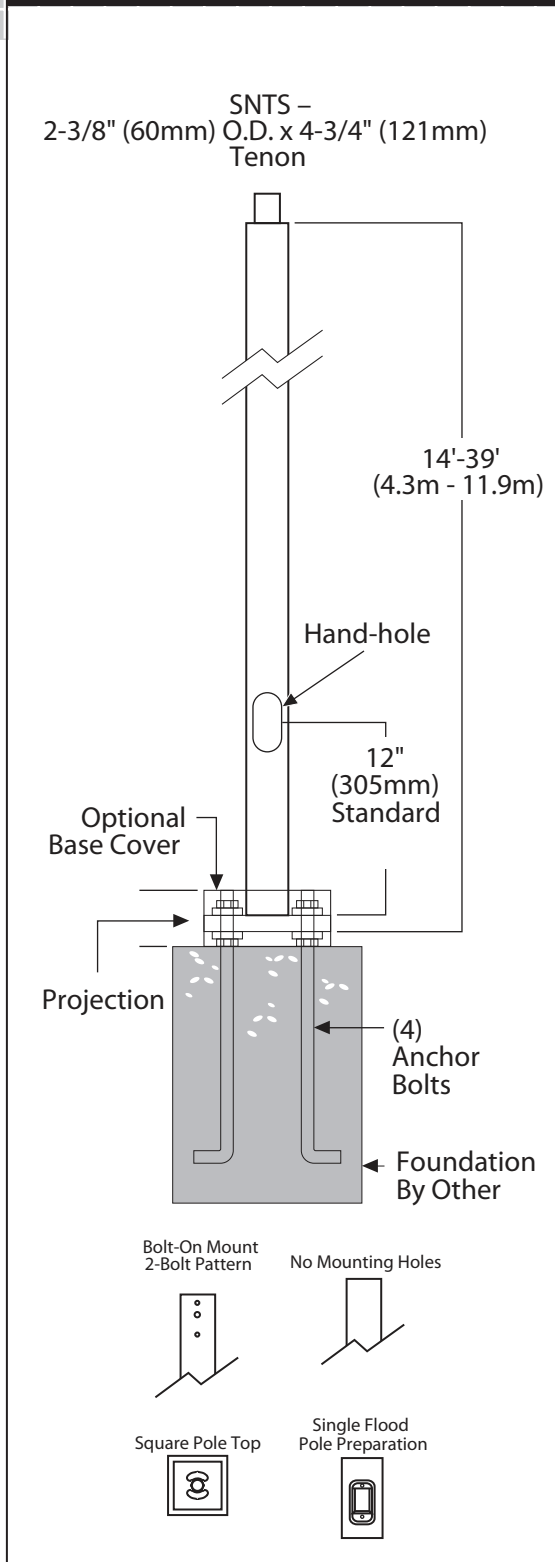

Approved By: _____ Project Name: _____

Location: _____ Date: _____

P.O. Box 100519 | Fort Worth, TX 76185 | 800.633.8711 | Fax: 817.735.4824 | www.wslighting.com

WLS LIGHTING SYSTEMS

Consider the Impact!

SNTS7 SQUARE NON-TAPERED STEEL SERIES

ORDERING INFORMATION SELECT APPROPRIATE CHOICE FROM EACH COLUMN TO FORMULATE ORDER CODE. Refer to example below.

CATALOG NUMBER ¹	MOUNTING CONFIGURATION	POLE TOP	FINISH	OPTIONS	ACCESSORIES
WLS-SNTS-20-4-7 WLS-SNTS-20-5-7 WLS-SNTS-22-4-7 WLS-SNTS-22-5-7 WLS-SNTS-24-4-7 WLS-SNTS-24-5-7 WLS-SNTS-24-6-7 WLS-SNTS-26-4-7 WLS-SNTS-26-5-7 WLS-SNTS-26-6-7 WLS-SNTS-28-5-7 WLS-SNTS-28-6-7 WLS-SNTS-30-5-7 WLS-SNTS-30-6-7 WLS-SNTS-35-6-7 WLS-SNTS-39-6-7	S - Single / Parallel D180° - Double D90° - Double DN90° - Double T90° - Triple TN120° - Triple Q90° - Quad QN90° - Quad PT - Pole Top N - Tenon Mount (Standard tenon size is 2-3/8" O.D.) I - For use with internal slipfitter	SBO - Square pole, bolt-on mount, 2 bolt pattern SPT - Square pole, pole top mount STM - Square pole, tenon mount SNH - Square pole, no mounting holes or pole top caps	BRZ - Bronze BLK - Black PLT - Platinum Plus BUF - Buff WHT - White SVG - Satin Verde Green GPT - Graphite MSV - Metallic Silver	GA - Galvanized Anchor Bolts SF - Single Flood DF - Double Flood DGP - DuraGrip® Plus LAB - Less Anchor Bolts NO - No Options	4BC - 4" Square Base Cover 5BC - 5" Square Base Cover 6BC - 6" Square Base Cover ER2 - Weatherproof Duplex Receptacle GFI - Ground Fault Circuit Interrupter MHP - Mounting Hole Plugs 4VD - Vibration Damper - 4" Square Pole 5VD - Vibration Damper - 5" Square Pole 6VD - Vibration Damper - 6" Square Pole NA - No Accessories

(EXAMPLE ORDER)

WLS-SNTS-35-6-7

D90°

STM

BRZ

NO

NA

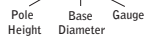

ORDER:
WLS-SNTS-

FOOTNOTES:

1 - Pole heights will have +/- 1/2" tolerance.

CATALOG NUMBER	SHAFT LENGTH	SHAFT SIZE	BASE PLATE	BOLT CIRCLE	ANCHOR BOLT SIZE	WT.	80 MPH EPA	90 MPH EPA	100 MPH EPA
WLS-SNTS-20-4-7	20'	4"	10-1/8" X 3/4"	8" - 11"	3/4" X 30"	200	12.8	8.8	5.9
WLS-SNTS-20-5-7	20'	5"	10-1/8" X 1"	9" - 11"	3/4" X 30"	250	25.1	18.4	13.4
WLS-SNTS-22-4-7	22'	4"	10-1/8" X 3/4"	8" - 11"	3/4" X 30"	220	12.6	8.4	5.4
WLS-SNTS-22-5-7	22'	5"	10-1/8" X 1"	9" - 11"	3/4" X 30"	275	23.9	17.0	12.0
WLS-SNTS-24-4-7	24'	4"	10-1/8" X 3/4"	8" - 11"	3/4" X 30"	240	9.7	6.0	3.3
WLS-SNTS-24-5-7	24'	5"	10-1/8" X 1"	9" - 11"	3/4" X 30"	300	19.6	13.4	8.9
WLS-SNTS-24-6-7	24'	6"	12" X 1-1/8"	12"	1" X 36"	370	32.6	23.2	16.6
WLS-SNTS-26-4-7	26'	4"	10-1/8" X 3/4"	8" - 11"	3/4" X 30"	260	7.2	3.9	1.5
WLS-SNTS-26-5-7	26'	5"	10-1/8" X 1"	9" - 11"	3/4" X 30"	325	15.8	10.3	6.3
WLS-SNTS-26-6-7	26'	6"	12" X 1-1/8"	12"	1" X 36"	401	27.3	18.9	12.9
WLS-SNTS-28-5-7	28'	5"	10-1/8" X 1"	9" - 11"	3/4" X 30"	350	12.5	7.5	3.9
WLS-SNTS-28-6-7	28'	6"	12" X 1-1/8"	12"	1" X 36"	432	22.7	15.1	9.6
WLS-SNTS-30-5-7	30'	5"	10-1/8" X 1"	9" - 11"	1" X 36"	375	9.6	5.0	1.7
WLS-SNTS-30-6-7	30'	6"	12" X 1-1/8"	12"	1" X 36"	462	18.6	11.6	6.6
WLS-SNTS-35-6-7	35'	6"	12" X 1-1/8"	12"	1" X 36"	539	10.0	4.3	-
WLS-SNTS-39-6-7	39'	6"	12" X 1-1/8"	12"	1" X 36"	601	4.3	-	-

EPA INFORMATION:

All WLS Lighting Systems' poles are guaranteed to meet the EPA requirements listed. WLS Lighting Systems is not responsible if a pole order has a lower EPA rating than the indicated wind-loading zone where the pole is located.

CAUTION:

This guarantee does not apply if the pole/bracket/fixture combination is used to support any other items such as flags, pennants, or signs, which would add stress to the pole. WLS Lighting Systems cannot accept responsibility for harm or damage caused in these situations.

Approved By: _____ Project Name: _____

Location: _____ Date: _____

WLS LIGHTING SYSTEMS