

GTH SERIES DECORATIVE

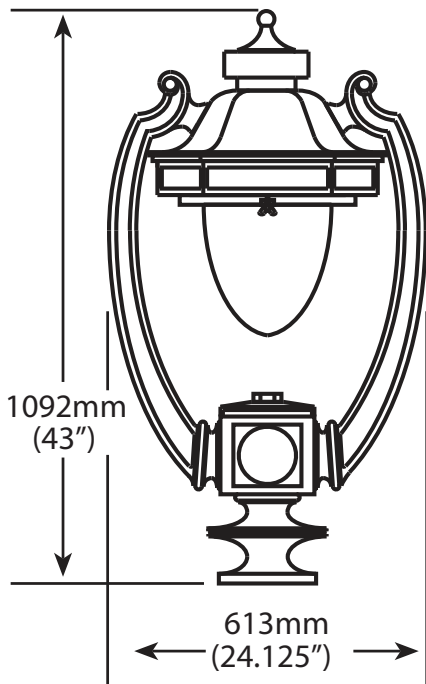

DIMENSIONS



Made in U.S.A.

SPECIFICATIONS

HOUSING - Heavy wall cast aluminum. Luminaire is shipped complete and ready to install.

OPTICS - High impact resistant, prismatic acrylic lens.

ARM - Multiple arm options below. Custom arm and mounting options available.

DRIVER - Xitanium Electronic LED Driver. LEDs are 50,000 hour rated.

LAMP - Metal Halide, Pulse Start Metal Halide, High Pressure Sodium and LED .

WARRANTY - Five year Limited warranty.

FINISH - Polyester powder fuse coating. Custom/special finishes available.

STANDARD MOUNT OPTIONS

Twin

Wall Mount

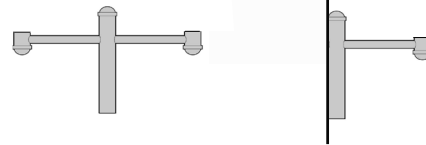

* Custom arms available upon request

ORDERING INFORMATION Refer to example below.

SERIES	LAMP WATT.	LIGHT SOURCE*	LIGHT DISTRIBUTION	LINE VOLTAGE	LUMINAIRE FINISH	MOUNT OPTIONS
GTH	50W 70W 100W 150W 175W 250W	MH - Metal Halide PSMH - Pulse Start Metal Halide HPS - High Pressure Sodium	3 - Type III 5 - Type V	120V 208V 240V 277V 480V MT - Multi Tap	BRZ - Bronze BLK - Black PLT - Platinum BUF - Buff WHT - White GRN - Green CC - Custom Color	PT - Post Top TW - Twin WM - Wall Mount
	68W 102W 136W	LED- LED - 3000K - 3500K - 4100K - 5000K	3 - Type III 5 - Type V	120V 277V		

GTH 102W LED 3 277V BRZ PT
(EXAMPLE ORDER)

ORDER :
WLS-GTH

Approved By: _____ Project Name: _____

Location: _____ Date: _____

P.O. Box 100519 | Fort Worth, TX 76185 | www.wslighting.com